

Lighta Min

LED Square High Bay

LHB5



Wattage
80W/110W



CCT
5000K



CRI
>70



Lifetime
50,000h



Efficiency
UP TO 135 lm/W

Lightweight & Compact Design makes it easy to install

Efficiency Up to 135 lm/W

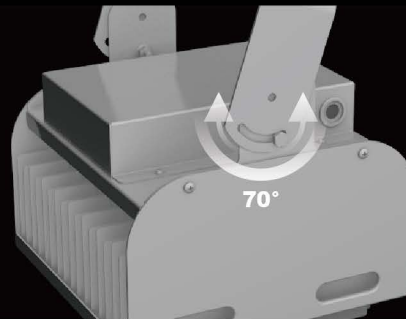
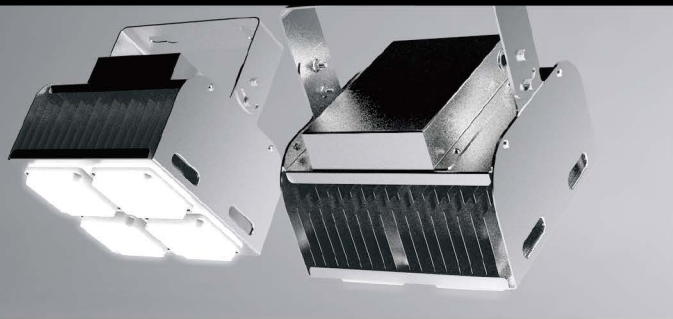

70°
Angle Adjustable

Long Lifetime
Reduce Replacements & Maintenance Cost



Use of top brand LED chips for longer life and superior output maintenance

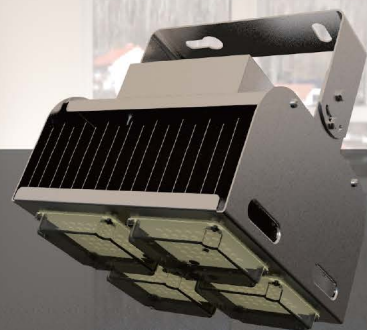

Color : Silver

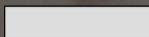

APPLICATIONS



Factory



Warehouse



Hypermarket



Gymnasiums



Distribution center

Based on the same condition of brightness



Mercury Lamp

400W



LED Square High Bay

110W

Annual bill for use of 40 high bays at 10hrs/day based on \$0.11kWh (U.S. Electricity Rate)

US\$6424

US\$1767

Cut Down **US\$4657** per year

Save 72%

Advanced Heat Dissipation

Special thermal design to enhance convective heat transfer for better heat dissipation performance

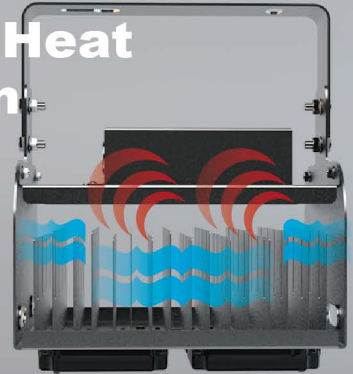

Aluminum heat sink

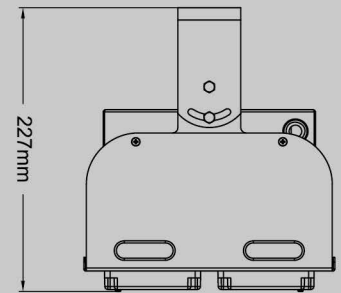
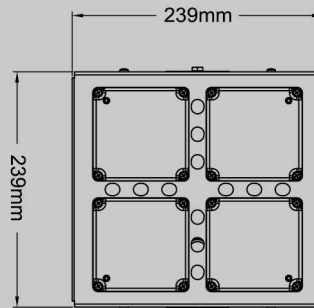

SIZE: 239L x 239W x 227H mm

Intensity(Unit:cd) **80W**

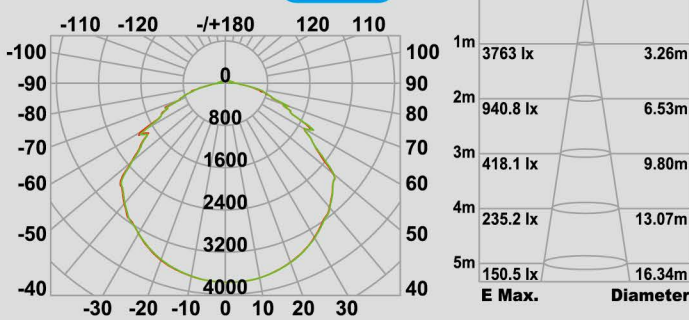

Intensity(Unit:cd) **110W**

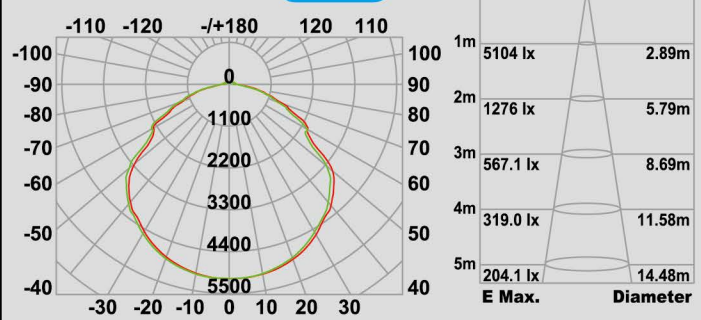

SPECIFICATION

Model	Power	Luminous Flux	Color Temp.	CRI	Beam Angle	Input Voltage	Input Current	Luminous Efficiency	Lifetime	IP Rating	Weight	Wattage Equivalent (Mercury Lamp)
LHB5080B	80W	10800 lm	5000K	>70	110°	120-277V or 100-240V	0.28-1.5A	135 lm/W	50,000 H	IP20	3.0Kg	350W
LHB5110B	110W	14850 lm					0.39-1.5A	135 lm/W			3.14Kg	500W



WENTAI TECHNOLOGY CORPORATION

6F-3, NO.123, Lane 235, Pao-chiao Rd,
Shintien District, New Taipei City, Taiwan
Tel:+886-2-89192318 Fax: +886-2-89192320

E-mail: inquire@a-wentai.com
www.wentailighting.com